

IN MOTION FOR YOU ...

Fall 2019

Volume 20, Issue 3



POBCO PLASTICS' BLUE ACETAL / DELRIN / UHMW / UXL MATERIALS DETECTABLE IN FOOD PROCESSING EQUIPMENT

POBCO offers many performance materials for specialty situations far above just a temperature limitation requirement. We are often confronted with requests for speed, dry running, abrasion resistance, chemical resistance as well as loads.

Our original material, POBCO B Lube filed hardwood, is unique for heavy loads as well as abrasion resistance and longevity. Our POBCO Plus adds lube to our UHMW for higher speeds and smoother operations. Our Hi-Wear is for just that as well as our Virgin Teflon that takes 550 degrees F.

And now our line of blue materials in "UXC", Delrin, and UHMW is detectable from many pieces of food processing equipment.

POBCO Blue "UXC" is primarily used as Guide material for Table Top and Roller Chain applications. This blend of UHMW has a coefficient of friction of 50% to 75% less than standard UHMW when used with Acetal, PET and Steel Table Top Chain. Other characteristics include: outstanding dry-running properties, FDA compliant, noise reducing, and eliminates the slip-stick effect (back-sliding).

Be sure to consult us on your unique requirements for your running applications as we more than likely can solve your production situation.

Inside this issue:

Our Sidewinder dramatically increases the life of your metal belting.	2
Traxx-Rite eliminates mis-tracking	8
Wiremation Filter Belts	8
Ashworth has you spiral belts	8
POBCO has the 2019 catalog out for all your conveyor com-	3
Lumsden's Edgewise stops tangles	4
Nx-Tec—MRO Items	5
NxKem Private Label Chemicals	6-7
REMCO keeps your cleaning organized	9
BS&k Can work for you	9
Featured Product—SuperLift	10

Special points of interest:

- **Lumsden** solves the dreaded problems of "belt snagging".
- **Wiremation** Introduces standard sprocket driven mesh belts
- **Wiremation** increases the life of your metal belts if stretch is the problem.
- **REMCO** can clean up your sanitation problems
- **Pobco** expands PET product offering and offers the new 2019 catalog

LUMSDEN BELTING SIDEWINDER HELPS REDUCE STRETCH AND MESH DAMAGE IN THE TOUGHEST APPLICATIONS—TRY US!

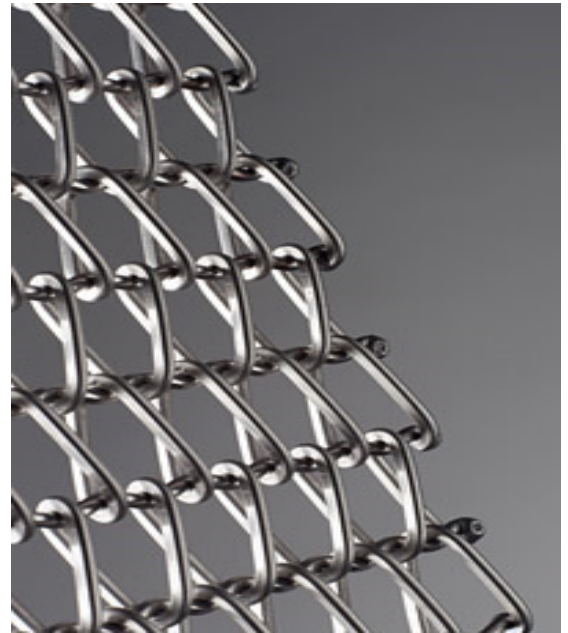

Lumsden introduces the new **Sidewinder Belt Family**.

Balance weave belting has been around for over 100 years with minor improvements over time. There are companies that offer round wire and some that offer top flattened wire, but none have been able to conquer the challenge of shaping the **sides** of the wire, until now.

Through years of R&D, Lumsden Belting has found the answer to everyone's question... How can I make my belts last longer? The answer is in the shape of the wire. With Lumsdens' patented side shaped wire design, you can extend your belt life up to **8 times** longer than your current comparable belt. And we are willing to prove it to you.

- Side shaped wire increases strength
- Flattened sides reduce carry over
- Greater open area.
- Minimal stretch
- Quick and easy to splice

With Lumsden's patented side flattened wire, the "I-beam" design gives 3 times greater structural support for your product versus the standard round wire.

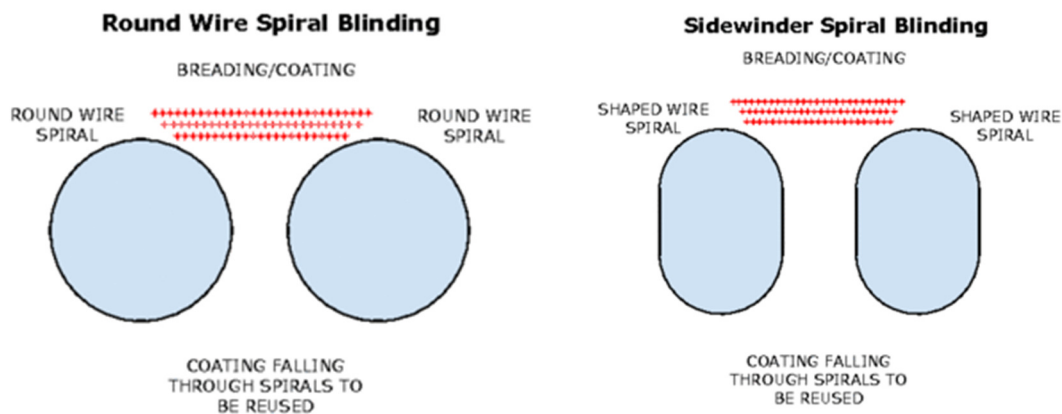



POBCO PLASTICS LATEST CATALOG HAS MANY NEW ITEMS TO REDUCE YOUR FRICTION AND YOUR COSTS

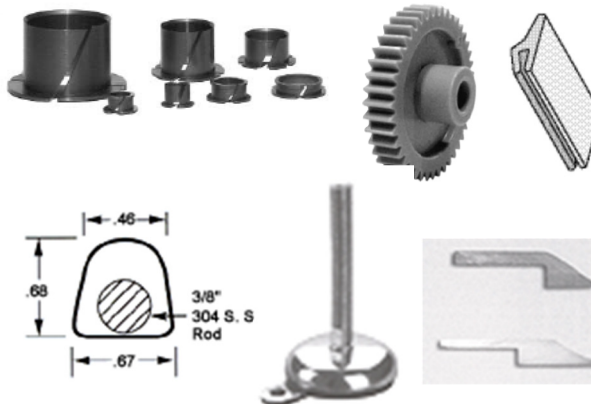
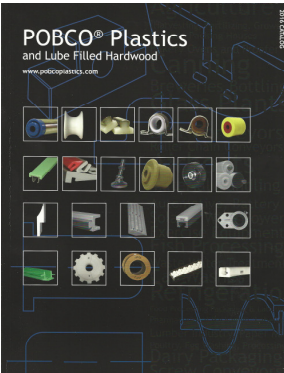

POBCO Products

- Plastic Guide Rails
- Plastic, Stainless Steel Brackets
- Rollers (Plastic, Steel & Wood)
- Bearings (Plastic & Wood)
- Plastic Sheet Stock
- Plastic & Wood Rod Stock
- FEP Shrink Fit Roll Covers
- Special Rollers
- Teflon Coated Fabric/Tapes/Belts
- Pressure Sensitive Plastic Adhesive Wear Tape

POBCO Capabilities

- Extruding
- Molding
- CNC Machining
- Screw Machining
- Turning
- Milling
- Routing
- Secondary Operations
- Assembly
- Custom Machined & Extruded Profiles & Shapes
- Die Cutting/Punching

POBCO Materials

- ULTRA-D® UHMWPE (Ultra-High Molecular Weight Polyethylene)
- Static Reduced UHMWPE
- UV Stabilized UHMWPE
- High Temperature UHMWPE (Fluid Lubricant-Filled UHMWPE)
- PLUS®
- Steel Filled UHMWPE
- High Wear CP, Black or Green
- Rulons® (Hi-Temp Food Grade 641, Bearing grades LR, J)
- Low & High Density Polyethylene (PE)
- Acetal (Delrin®, Celcon®)
- Delrin AF® (Teflon Filled Acetal)
- Delrin® (Also Lube-Filled & Oil Filled Types) (Solid Lubricant-Filled Delrin) (Fluid Lubricant-Filled High Temperature Plastic) (Lubricant-Filled Grey Nylon) (NylatronGS®)
- DELLUBE
- Nylon
- NYLUBE
- Nylon MD
- PVC (Polyvinyl Chloride) (High Heat Plastics) PTFE®
- Glass Filled (Urethane: Specify Durometer Reading & Color)
- TEFLON®
- Teflon
- POLYURETHANE
- POLYPROPYLENE
- Flurosint 207® (High Heat)

POBCO® Guides and Accessories Overview

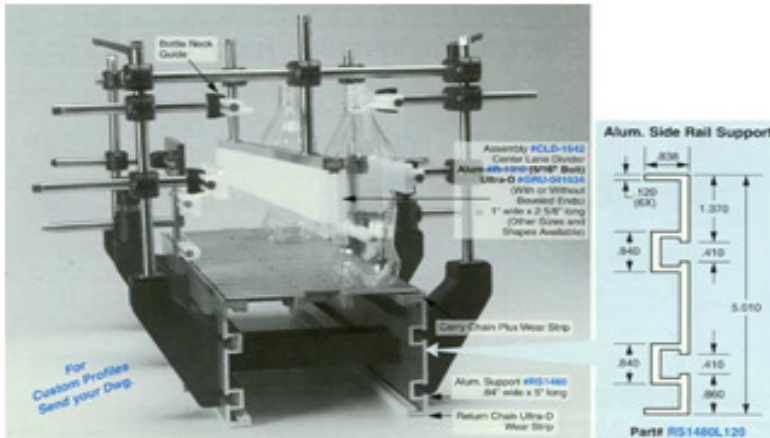



LUMSDEN'S EDGEWISE BELT HAS DRASTICALLY REDUCED BELT WASTE DUE TO TANGLING



Lumsden's **Edgewise** edge has proven to many customers that this design prevents tangling and catching of the wires both on and off the machine. They come off the rolls un-tangled, they don't catch on adjoining belts, and there are no ends to bend open and break.

Less downtime, less scrap and with the buffed edge, less cut hands. A real winner in all cases.

With the **Edgewise** edge, wires do not have to be opened and then closed again to splice belt. This prevents the ends from breaking off, and having to re-splice the belt, like other belts do.



Don't forget your drive components!

We can supply the sprockets, idle rollers, nose rollers as well as the wear strips and belt supports. The nose rollers, in addition to tracking, protect the "Z" bends of the belt. By replacing them before they wear down, you can increase the life of the belt and extend maintenance intervals. Let us show you how we can save you money.



LUMSDEN FLEX TURN BELTS, THE NEXT GENERATION IS HERE .

Lumsden has the new and improved Flex Turn Belt. This belt is made to precise tolerances and without any splice clips that can harbor bacteria.

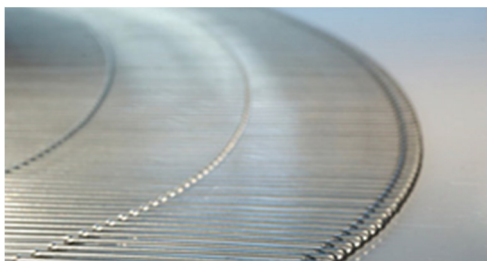

Lumsden Turn Belt - Look, no tubes!



Edgewise "Snag-free" edges

Our longer belt edge greatly reduces tangling during installation and improves operator safety by making it virtually impossible to snag.



Typical Competition Belt Edge



Lumsden Belt Edge

Our belt is a "drop on" belt that requires no modifications to your existing conveyor. We'll be happy to show you the difference.

Nxtec Sales Group Inc.

Janitorial

- Waste Receptacles & Can Liners
- Floor & Carpet Care
- Chemicals & Odor Control
- Paper Products & Dispensers
- Skin Care
- Mopping Equipment
- Floor Maintenance Equipment
- Floor Pads, Sponges & Abrasives
- Brooms, Brushes & Accessories
- Matting & Utility,
- Cleaning Tools
- Material Handling & Packaging
- Healthcare Amenities
- Food Service & Facility Maintenance



Tools

- Abrasives & Adhesives
- Bits - Carbide, Drill, Insert, Power
- Sealants & Tapes
- Chemicals
- Fluids & Lubricants
- Electrical & Lighting
- Hand Tools
- HVAC & Hydraulic Tools
- Machinery & Supplies
- Plumbing Equipment
- Pneumatic Tools
- Power Tools & Pumps
- Safety & Security
- Storage Products



Safety & First-Aid

- Clothing
- Disposable Apparel
- Environmental Absorbents
- Ergonomics
- Head, Eye & Face Protection
- Safety Glasses & Readers
- Fall Protection
- First Aid Kits
- First Aid Refills / Service
- Footwear
- Hard Hats
- Leather Gloves
- Disposable Gloves
- Hearing Protection
- Ear Plugs - Corded, Un-corded
- Monitors & Detection Equipment
- Respiratory Protection
- Safety Matting
- Signs/Barriers/Traffic
- CUSTOM Signs



Fasteners

- Anchors
- Anchor Kits
- Assortment Kits (Plastic & Steel)
- Cable Ties
- Cap Screws
- Carriage Bolts
- Custom Fasteners
- Drywall Screws
- Electrical Connectors
- Elevator Bolts
- Eye Bolts & Nuts
- Flange Screws
- Frame Bolts
- Industrial Hardware
- Lag Screws
- Machine Screws
- Metric - Bolts, Fasteners, Nuts
- Nuts & Bolts
- Pins - Cotter, Spring, Roll, Spring
- Self-Drilling Screws
- Sheet Metal Screws
- Socket Screws - Cap, Set, Shoulder
- Square Head Bolts
- Step Bolts
- Structural Bolts
- Surplus Stock
- Tamperproof Fasteners
- Tap Bolts
- Thread-Cutting Screws



Name Brands You Know....

- 3M • AOS • Georgia Pacific
 - Kimberly-Clark • DeWalt • CGW
 - Rigid • Jaguar Plastics • InFasco
 - RubberMaid • Norton • Swift
 - West Chester • Pyramex • Gojo
 - Smith & Wesson • Allegro • Tapco
 - Loctite • North Safety • Safco • Hon
 - HP • Xerox • Sharp • Dixie
 - Pullman-Holt • Unger • Makita
 - Victor • Memphis • Crews • Eagle
 - Spilltech • Tennesco • Clorox • Dial
 - SK Tools • DuPont • Microflex
- Just to Name a Few....

Office Products

- Binders & Binding Supplies
- Calendars, Planners & Briefcases
- Cash/Check Handling
- Computer Hdware, Supplies & Storage
- Files & Filing Supplies
- Forms, Record Keeping & Reference
- Furniture & Room Accessories
- Lunchroom Supplies
- Labels, Label Makers
- Tags & Stamps
- Mailroom & Packing Materials



Environmental Items

- Acid Absorbent
- Booms & Socks
- Cell-U-Sorb Absorbent
- Floor Absorbent
- Industrial Cleaners
- Oil Absorbent
- Protective Wear
- Safety Cabinets
- Solvent Free Cleaners
- Spill Control & Containment
- Waste Digesters



Specialty Products

- OUR SPECIAL ORDERS DIVISION FOR NON-STOCK REQUESTED ITEMS HAS A FILL RATE OF 99%..
- WE CAN FILL MOST ANY REQUEST, ACCURATELY WITH PROMPT DELIVERY.

(800) 634-1114

We are a Preferred Vendor to many Fortune 500 Companies, and many Federal, State, & County Governments. With multiple shipping locations strategically located, we offer our customers fast and prompt service with a fill rate of 99% most anywhere in the United States.

Nxtec would like the opportunity to earn your business! No customer is too big or small. We know that once you experience our personalized service, you will know why other companies prefer doing business with an industry leader.



PROFUCHELISHING

- XN-1030 FUSIONBOND 370A - 50ML SYRINGE
- XN-1020 E6000 MULTI PURPOSE ADHESIVE CLR
- XN-1025 E6000 MULTI PURPOSE ADHESIVE BLK
- XN-1030 SOLUTION 6 *DEBONDER AND CLEAN UP AGENT
- XN-1035 SOLUTION 30 PIPE SEALANT WITH TEFLON 50 ml
- XN-1040 SOLUTION 30 PIPE SEALANT WITH TEFLON 250 ml
- XN-1045 SOLUTION 1 *FAST INSTANT ADHESIVE .33 FL OZ
- XN-1050 SOLUTION 1 *FAST INSTANT ADHESIVE (1 FL OZ)
- XN-1055 SOLUTION 3 *GENERAL, INSTANT ADHESIVE .33 FL OZ
- XN-1060 SOLUTION 3 *GENERAL, INSTANT ADHESIVE (1 FL OZ)
- XN-1065 SOLUTION 1800 *ANTISEIZE ALLUM, COPPER, & GRAPHITE
- XN-1070 SOLUTION 2500 *METAL FREE ANTISEIZE USDS
- XN-1075 SOLUTION 2600 *NICKEL & GRAPHITE ANTISEIZE
- XN-1080 SOLUTION 11 *HIGH STRENGTH RED THREADLOCKER
- XN-1085 SOLUTION 10 *MEDIUM STRENGTH BLUE THREADLOCKER
- XN-1090 SOLUTION 34 *HYDRAULIC - PNEUMATIC SEALANT 10ml
- XN-1095 SOLUTION 34 *HYDRAULIC - PNEUMATIC SEALANT 50ml
- CARPET CARE**
- XA-1500 SPOT B GONE *SPOT REMOVER CARPETS OR UPHOLSTERY
- XA-1510 BA-ZOO-CA *CHEWING GUM & WAX REMOVER
- XA-1520 POWDER UP *DRY FOAM CARPET CLEANER
- XL-1500 X-TRACTION *CARPET CLEANER
- XL-1510 VANISH *CARPET SPOTTER & LAUNDRY FRESHEN
- XL-1520 D-FOAM-A-TRATE MULTI-PURPOSE FOAM CONTROL CON
- XL-1530 REPRIMAND *PREMIUM CARPET AND UPHOLST SHAMPOO
- XL-1540 REMOVES-ALL *CARPET PRE-SPOTTER AND DEODORIZER HD
- XL-1550 HUSKY 1100 *CONCENTRATE 3 IN 1 TRAFFIC LANE PRE-SPRAY
- XL-1560 REVIVER *FAST ACTING SPOTTER & PRE-TREATMENT
- XN-1500 ODOR OUT *LEMON CARPET FRESHENER
- XN-1505 ODOR OUT *BOUQUET CARPET FRESHENER
- CLEANERS**
- XA-2000 GLEAM-ON *PREMIUM GLASS & SURFACE CLEANER
- XA-2005 NEON MOON *GLASS AND HARD SURFACE CLEANER
- XA-2010 BBO MAX *ALL PURPOSE CLINGING FOAM CLEANER
- XA-2061 ICEE *FOAMING NO RINSE COIL & FIN NON-ACID
- XA-2070 VEPER *CITRUS FOAMING COIL AND FIN CLEANER
- XA-2100 ZHO ZAO *BIO-ENZYM, ALL N-1 BATHROOM CLEANER
- XA-2110 AIR HEAD *MOISTURE FREE, HIGH PRESSURE AIR DUSTER
- XA-2121 BBO ORANGE *FOAMING CITRUS DEGREASER
- XA-2130 OMO *HD FOAM CLEANER
- XL-2011 PREDATOR *24% HCl ACID BOWL CLEANER
- XL-2020 KEM DELA CREME *CREAM KITCHEN & BATH CLEANER
- XL-2030 PROXY OXY *PEROXIDE SPRAY & WIFE CLEANER RTU
- XL-2040 CITRUS ATTACK *HEAVY DUTY CLEANER DEGREASER
- XL-2050 WHITE LIGHTN *ORBIT, MILDEW & STAIN REMOVER
- XL-2060 BLUE BELLE *PORCELAIN STAIN & ODOR REMOVER
- XL-2070 BIO-ZYME *BIO WASTE DEGRADER, DEODORIZER
- XL-2081 CURVE BALL II *ENVIRO HD-GREASE AND GRIME CLEANER
- XL-2090 911 *OVEN, GRILL AND FRYER CLEANER
- XL-2100 MUSCLE *HIGHLY CONCENTRATED EMULSIFIERS
- XL-2110 BREAKING THROUGH *STREAM CLEAN & POWER WASH CONC.
- XL-2120 GROUT BUSTER *RESTORES GROUT TO ORIGINAL COLOR
- XL-2140 BRILLIANT *WASH & WAX CONCENTRATE
- XL-2150 PURE VUE *CONCENTRATED (20-1) GLASS CLEANER
- XL-2155 PURE VUE *GLASS CLEANER QRTS RTU
- XL-2160 IMPACTED *AGGRESSIVE BUTYL CLEANER
- XL-2170 INHIBITOR 20% *PHOSPHORIC DE-SCALER, RUST REMOVER
- XL-2180 CAR & TRUCK WASH *HIGH SUDS AND LOW RINSE CON
- XL-2190 HOO WILD *STEAM CLEANING LOW FOAMING LIQUID
- XL-2210 RENEW FOAMING *COIL CLEANER, BRIGHTENER
- XL-2220 GREEN GIANT *NON-BUTYL HD INDUSTRIAL DEGREASER
- XL-2230 SCALE AWAY *FOAMING COIL CLEANER AND BRIGHTENER
- XL-2240 JOHNNY ON THE SPOT *SCALE AND ODOR CONTROL
- XL-2250 MR FREEZE *ICE MACHINE CLEANER DESCALER
- XL-2260 RE-KOIL *NON ACIDIC FOAMING COIL CLEANER 10 to 1
- XL-2270 FOAMING COIL CLEANER 3 to 1 *CONCENTRATE NON-ACID
- XL-2280 PREVENT *EXTRA HEAVY DUTY COIL CLEANER
- XL-2300 LLISTER *CONCRETE CLEANER & ETCHER
- XL-2305 LLISTER-MAC *MECHANIC ACID CLEANER
- XL-2310 XTEND *COIL CLEANER & INOXIDIZER LIQUID
- XL-2320 GLISTEN *GLASS CLEANER AMMONIA FREE
- XL-2330 CRUSH *HD BUTYL CLEANER & DEGREASER
- XL-2340 NO CHANCE *COMPLETE KITCHEN MAINTAINER
- XL-2350 MARVELOUS *ALL PURPOSE CLEANER & DEODORIZER
- XL-2360 SWIRL *NON-ACID BOWL & PORCELAIN CLEANER
- XL-2390 CELESTE *HAND DISHWASHING CONCENTRATE, HIGH SUDS
- XN-2390 CARNIVOR *HEAVY DUTY CONCRETE CLEANING POWDER
- XN-2490 A-TEC *POWDER ALUMINUM TRANSMISSION & ENGINE CLEAN
- XP-2410 *JAWS TILE, GROUT & BATH CLEANER/DEO STARTER KIT
- XP-2421 *JAWS GLASS & HARD SURFACE CLEANER 24PK
- XP-2421 *JAWS GLASS AND HARD SURFACE CLEANER STARTER KIT
- XP-2423 *JAWS LIQUID MALODOR COUNTERACTA (MOUNTAIN FRESH)
- XP-2423 *JAWS LIQUID MALODOR COUNTERACTA STARTER KIT
- XP-2425 *JAWS BUCKET PACK DEEP SCRUB MULTI CLEANER
- XP-2427 *JAWS BUCKET PACK NEUTRAL DAMP MOP CLEANER
- XP-2429 *JAWS MULTI PUR CLEANER/DEGREASER (STARTER KIT)
- COATINGS**
- XA-2501 OVER & UNDER *RUBBER COATING UNDERCOAT BLACK
- XA-2510 LIKE NEW *FOAMING TIRE/VINYL REJUVENATOR
- XA-2511 OVER & UNDER *RUBBER COATING UNDERCOAT WHITE
- XA-2512 OVER & UNDER *RUBBER COATING UNDERCOAT CLEAR
- XA-2520 NI-DIME *NF DETAILING WATERMELON DRESSING
- XA-2540 CONVERT *RUST CONVERTER / PROTECTIVE COATING
- XA-2550 DUSTY *FURNITURE POLISH LEMON OIL
- XA-2570 MICKY'S BEST *PREMIUM LONG LASTING WAX AND SHINE
- XA-2580 PRO TEK *INDUSTRIAL METAL PARTS PROTECTOR
- XA-2590 GREPPER *SLIP RESISTANT EPOXY COATING BLACK, CLEAR, GRAY & SAFETY YELLOW
- XA-2600 SSC 1 *STAINLESS STEEL COATING
- XA-2610 KEMOLEM *HIGH SOLED FLAT BLACK, FLAT WHITE, GLOSS BLACK, GLOSS WHITE, SAFETY BLUE, SAFETY GREEN, SAFETY ORANGE, SAFETY RED, SAFETY YELLOW PAINT, PRIMER GRAY & PRIMER RED
- XA-2620 ZEBRA *FLUORESCENT SAFETY GREEN, ALERT ORANGE, YELLOW, PRE CAUTION BLUE MUNICIPAL MARKING PAINT
- XA-2630 ROAD RUNNER *TRAFFIC STRIPING PAINT WHITE, HANDICAP BLUE, YELLOW
- XA-2650 ROCK HARD *SURFACE PROTECTANT
- XA-2660 STONER *MARBLE & GRANITE CLEANER

- XA-2730 30 *PURE ZINC COLD GALVANIZE SPRAY
- XA-2760 SHIELD *STAINLESS STEEL & DELICATE METAL CLEANER
- XA-2770 CHARGER *BATTERY TERMINAL CLEANER & PROTECTOR
- XA-2780 OPTIFLEX *ANTI-STATIC COMPUTER SCREEN CARE
- XA-2784 OPTI-MAX *VISUAL SURFACE ENHANCER
- XA-2790 SHOUT *ACOUSTICAL TILE RESTORER
- XL-2500 SURE FOOT *HD NON SKID 1-PART EPOXY BLACK, LT GRAY, DARK GRAY, GREEN, RED, YELLOW, BEIGE
- XL-2510 SURE FOOT II *HEAVY DUTY NON-SLIP RUBBERIZED BLACK, HAND-BLUE, YELLOW, GRAY, RED, GREEN, NAVY
- XL-2520 PINNACLE *EPOXY ESTER FLOOR ENAMEL DURABLE WHITE, LT GRAY, RED, DK GRAY, YELLOW, BLACK
- XL-2530 AFM *FIELD MARKING PAINT WHITE
- XL-2550 OVER & UNDER *RUBBER UNDERCOATING BLACK BULK
- XL-2560 REPLAY *GRAFFITY PROTECTANT
- XL-2570 30 *COLD ZINC GALVANIZE COATING BULK 5-GALLONS
- XL-2600 SLICK *ASPHALT RELEASE
- XL-2610 FLOW *SILICONE WAX FOR SNOW TREATMENT
- XL-2620 SENTINEL *ASPHALT SEALER
- XL-2630 DUR-A-KOTE ACRYLIC POLYMER SEALER
- XL-2640 ROAD RUNNER *BULK TRAFFIC STRIPING PAINT
- XL-2700 DURAGARD *EPOXY FLOOR COVERING
- XN-2500 MET-ALL BRASS & COPPER POLISH 2.5OZ
- XN-2505 MET-ALL ALUMINUM & STAINLESS POLISH 2.5OZ
- XN-2510 MET-ALL SILVER & PEWTER POLISH 2.5OZ
- DEODORANTS**
- XA-3000 QDC *ENZYMATIC FOAMING ODOR CONTROLLER
- XA-3010 NATURAL SCENTS ODOR ELIMINATOR *MELON, MULBERRY, TUTTI FRUTTI, VANILLA, APPLE, BERRY BERRY, COUNTRY GARDEN, ORANGE CITRUS, PEACHY, SWEET MANGO
- XL-3000 SENSORY *HIGH CONCENTRATE DEODORANT CLEAN SCENT
- XL-3010 CC-1 *CONCENTRATED CINNAMON DEODORIZER
- XL-3020 OVERTONE II *OIL BASED COUNTERACTANT & ODOR CONTROL
- XL-3030 BA-DA-BING *POWERFUL CHERRY DEODORIZER
- XL-3050 SWELL JEL *FRESH-N-CLEAN LONG LASTING ODOR CONTROL
- XL-3052 SWELL JEL *GREEN APPLE LONG LASTING ODOR CONTROL
- XL-3054 SWELL JEL *ORCHARD SPICE LONG LASTING ODOR CONTROL
- XL-3056 SWELL JEL *PLUMERIA LONG LASTING ODOR CONTROL
- XN-3015 DRIBBLE COMMODE *FLOOR MATS BLK
- XN-3020 DRIBBLE URINAL *FLOOR MATS BLK
- XN-3030 URINE I *FLAT URINAL SCREENS BUBBLE GUM & CHERRY
- XN-3040 I.Q. DEODORIZING DISKS 12PK
- XN-3045 ROYAL AIR *AIR FRESHENER DISCS
- XN-3050 URINE II *URINAL SCREENS W BLOCK FRESH-N-CLEAN GREEN APPLE
- XN-3055 FIVE-RAY PLUS *URINAL MAINTEN BLOCK CINNAMON & GREEN APPLE
- XN-3060 RIMMIE *TOILET RIM CAGES WITH BLOCK FRESH-N-CLEAN GREEN APPLE
- XN-3070 BUCKET O HEADS *CHERRY, FRESH-N-CLEAN, GREEN APPLE, ORANGE, ORCHARD SPICE, PEACH, PLUMERIA, SEA BREEZE, STRAWBERRY, TEA ROSE, VANILLA, WATERMELON 24-1OZ
- XN-3080 FUSION-TELL *REFILL BLUE SPLASH, CRYSTAL BREEZE, CITRUS, POLAR MIST, VANILLA CREAM, WAKENING SPRING
- XN-3090 GEL-O *AIR NEUTRALIZER REFILL CHERRY BERRY, COUNTRY DELIGHT, CINNAMON SPICE, DELICIOUS APPLE, LINDEN FRESH, MANDARIN ORANGE, MOUNTAIN SPA, OCEAN BREEZE, VITA SPLASH
- XN-3110 LE FEW *DUMPSTER, CAN & REFUGE DEODORANT
- XN-3120 DUMPSTER DAISY *CHERRY DEODORANT GRANULES
- XP-3000 PUMP *PURE ODOR ELIMINATOR 9% V.O.C., VITA SPLASH, MOUNTAIN PEAKS, TROPIC, VANILLA, MANDARIN ORANGE, SANTA FE, OCEAN BREEZE, COUNTRY DELIGHT
- XP-3010 SMELL SWELL METERED SPRAY *BABY POWDER, CHERRY, CINNAMON, FLORAL BOUQUET, GREEN APPLE, BLAND MANGO, LEMON FRESH, MULBERRY, NIRVANA, ORANGE BURST, NEUTRALIZER, ORIENTAL SPICE, TROPICAL FLOWERS, VANILLA
- XP-3030 AUTO-JANITOR *LINDEN FRESH, MANDARIN ORANGE, COUNTRY DELIGHT, BBO-FLUSH CLEANER DEODORIZER REFILL
- DISINFECTANTS**
- XP-3802 *JAWS FOOD SERVICE SANITIZER STARTER KIT
- XP-3803 *JAWS FOOD SERVICE SANITIZER 24PK
- XP-3805 *JAWS DISINFECTANT CLEANER DEGREASER 24PK
- XP-3805 *JAWS DISINFECTANT CLEANER DEGREASER STARTER KIT
- XP-3806 *JAWS BUCKET PORTION PACK NEUTRAL DISINFECTANT
- XP-3500 STAF *AIR SANITIZER EPA QUAT/DISINFECTANT
- XP-3502 SANS-GUARD *DRY CONTACT SURFACE SANITIZER
- XP-3503 SANS-GUARD *DRY CONTACT SURFACE SANITIZER
- XP-3505 ZENATIZE COUNTRY *FOAM DISINFECTANT & DEODORANT
- XP-3510 ZENATIZE COUNTRY *DISINFECTANT & DEODORANT
- XP-3515 PISTOL *EPA QUAT, CLING, FOAMING CLEANER
- XP-3516 804 FOAMING NON-ACID DISINFECTANT CLEANER
- XP-3521 QD-64 Lemon EPA QUAT, HIV-1 DISINFECTING, DELTITES 64-1
- XP-3526 QD-64 Pine EPA QUAT, HIV-1 DISINFECTING, DELTITES 64-1
- XP-3536 QD-64 Mint EPA QUAT, HIV-1 DISINFECTING, DELTITES 64-1
- XP-3540 TOTAL GREEN *NEUTRAL DISINFECTANT CLEAN MINT
- XP-3540 NEUTRA-CLEAN NEUTRAL DISINFECTANT CLEANER
- XP-3550 CONQUER TBO *RTU QUAT CLEANER CLEAN & FRESH
- XP-3560 VANQUISH *5.5% MULTIPLE QUAT NO FRAGRANCE
- XP-3570 891 *ARENA DISINFECTANT, KILLS HUMAN CORONA VIRUS
- FLOOR CARE**
- XA-4000 STRIP IT *FOAMING BASEBOARD STRIPPER, CLEANER
- XA-4010 MAGNET *DUST MOST TREATMENT
- XL-4000 FLAIR 22% *FLOOR ULTRA HIGH GLOSS XTRA LONG WEAR
- XL-4010 STRIP ALL *ULTRA AMMONIATED FLOOR STRIPPER
- XL-4020 WINTERISE *FLOOR RESE NEUTRALIZES ICE MELT
- XL-4030 PENETRATE *CLEAR CONCRETE SEALER NON-YELLOWING
- XL-4040 TITANIUM 25 *ULTRA BRIGHT FLOOR FINISH
- XL-4050 SUPER JEL *FINE CONCENTRATED CLEANER & DEGREASER
- XL-4060 DEEP GLOSS 18 *HIGH GLOSS ECONOMY FLOOR FINISH
- XL-4070 JMS OYM & WOOD FLOOR FINISH * LOW VOC HIGH GLOSS REFLECTION *OIL MODIFIED URETHANE
- XL-4080 HD STRIPPER *HEAVY DUTY NON-AMON FLOOR STRIPPER
- XL-4120 ODOF PROOF *SPRAY FLOOR REJUVENATOR
- XL-4140 304-6010 FLUFFY *WAX BASED FLOOR SWEEPING COMPOUND
- 304-6015 GRITTY *OIL BASED SWEEPING COMPOUND
- 304-6000 702 NO RINSE *NEUTRAL CLEANER
- GROUND**
- XL-4500 SUPER SURFACTANT *WATER SOLUBLE SPREADER
- 304-4500 BARREN AEROSOL *NON-CROPLAND HERBICIDE (AEROSOL)
- 304-4500 BARREN *NON-SELECTIVE HERBICIDE #2 W/ RESIDUAL CON
- 304-4505 ELIMINATOR DQUAT AQUATIC WEED & ALGAE HERBICIDE

PRODUCT LISTING

WEED CONTROL
 XR-4520 ZAP IT ULTIMATE *18% GLYPHOSATE SPOT WEED CONTROL
 XR-4525 TURF KING *LAWN & TURF WEED 3.75% PROMETON CONCEN
 XR-4530 WEED EASY *GRANULAR HERBICIDE NON-SELECTIVE
 XR-4535 TRIPLE THREAT LIQUID *BROADLEAF CONTROL, DILUTABLE
 XR-4540 SELECTIVE HERB 43 *BROADLEAF, BRUSH AND STUMP KILL
 XR-4545 PROMETON 12.5% *HERBICIDE CONC- SUPER RESIDUAL
 XR-4550 LIQUID FERTILIZER *4-8 STIMULATES HEALTHY, DEEP ROOT
 XR-4555 LIQUID FERTILIZER *20-2-3 FOR SPRING OR EARLY SUMMER
 XR-4560 LIQUID FERTILIZER *16-8-4 GENERAL PURPOSE FERTILIZER
 XR-4565 CHELATED IRON *CURES & PREVENTS IRON DEFICIENCIES
 XR-4570 SURFACTANT *INCREASE EFFECTIVENESS OF GROUND MAIN
 XR-4575 RITE HITE *CONCENTRATED LIQUID GROWTH RETARDANT
 XR-4580 BANISH *NON-SELECTIVE ROOT KILLER

LUBRICANTS
 XA-5000 CUT EZZZZ *RTU COOLANT & LUBE FOR CUT & TAP FLUID
 XA-5020 SLIP KNOT *SILICONE LUBE FAST DRYING NON-STAINING
 XA-5031 BLACK DIAMOND *DRY FILM LUBRICANT AND COATING
 XA-5040 TACKY *PENETRATING GEL LUBRICANT WITH PTFE
 XA-5050 RED ZONE * RED SPRAY GREASE LITHIUM BASED NC
 XA-5060 GEAR HEAD *OPEN GEAR & CABLE LUBRICANT, HIGH TACK
 XA-5070 ALL THE WAY *OIL CHAIN & CABLE LUBRICANT
 XA-5080 WHITE KNIGHT *FOOD GRADE GREASE ULTRA PURE
 XA-5090 BEST D997 LUBE *MULTI PURPOSE LUBE
 XA-5100 TIGHTY WHITEY *DRY LUBRICANT & RELEASE AGENT
 XA-5110 BARRICADE *MOISTURE DISPLACER AND PROTECTANT
 XA-5120 AIR TOOL CLEANER & LUBE
 XA-5130 EXTREME ANTI-SEIZE COMPOUND
 XL-5000 KOOLHAND-4110-D *METAL WORKING FLUID CONC
 XL-5005 KOOLHAND SUPER-9933 *SUPER CONCEN METAL WORKING
 XL-5010 MAJESTIC *OIL GREASE LUBE-ESW 140 GEAR LUBRICANT
 XL-5020 ALADDIN *VANISHING FLUID 1044-DO
 XL-5030 MOJO HYDRAULIC OIL AW-32
 XL-5040 KWIK CUT *CUTTING AND TAPPING OIL - Z20
 XN-5010 SUPER IMPACT GREASE *MULTI-PURPOSE GREASE
 XN-5020 2ACT GOLD *ULTRA PREMIUM OVERBASED GREASE
 XN-5030 ULTRA BLUE *COMPLEX E.P. GREASE
 XN-5040 WHITE KNIGHT *FOOD GRADE WHITE GREASE
 XN-5050 RED BOOSTER *EXTREME PRESSURE NON-MELTING GREASE
 XN-5060 METALLICA *ULTRA HI-TEMP SYNTHETIC BLEND GREASE
 XN-5070 MC-2 *MULTI-PURPOSE MOLY GREASE
 XN-5080 MR GREEN *LITHIUM EP, NLGI, GREEN BULK
 XN-5090 BHO RED *NON-MELT, HIGH POLYMER, NLGI 2.5 RED BULK
 XN-5040 MOLY TUFF *NON-MELT E.P. MOLY,NLGI 1.2, BLACK BULK

PATCHING
 XA-5500 EXPANDO *EXPANDABLE INSULATION FOAM SEALANT
 XA-5510 LOCK OUT *ROOF PATCH
 XA-5550 REAL DEAL *CLEAR RTV CAULKING WITH MILDICIDE
 XA-5660 REAL DEAL *WHITE RTV CAULKING WITH MILDICIDE
 XA-5670 REAL DEAL *BLUE *RTV GASKET SEALANT ADHESIVE
 XA-5680 REAL DEAL *RED *RTV HIGH TEMP GASKET SEALANT
 XA-5690 REAL DEAL *BLACK *RTV GASKET MAKER SEALANT
 XL-5500 FLEX-O-POUR *COLD APPLIED FLEXIBLE CRACK SEALER
 XL-5505 CONCRETE COLD POUR *CRACK SEALER (GRAY)
 XL-5510 BOX-LITE *ALUMINUM FIBERED ASPHALT ROOF PATCH
 XL-5530 FOUR SEASONS *ALL WEATHER ROOF PATCH
 XN-5500 DURA-BOND *COMMERCIAL GRADE ASPHALT PATCH
 XN-5505 KEM-KRETE *MULTI-PURPOSE CONCRETE PATCH
 XN-5510 KEM-KRETE-PLUS *PREMIUM LATEX CONCRETE PATCH
 XN-5520 RAPID SEAL *EMERGENCY FLAT ROOF REPAIR
 XN-5530 A-PPXIC *POURABLE CONCRETE PATCH WITH VINYL
 XN-5550 TRIPLECTA *PREMIUM RESURFACING EPOXY PATCH
 XP-5500 TITANIUM *EPOXY REPAIR & REBUILD WITH TITANIUM
 XP-5501 FAST STEEL *EPOXY STEEL REPAIR
 XP-5502 AQUA MEND *EPOXY FIBERGLASS REPAIR
 XP-5503 INSTA CRETE *EPOXY CONCRETE REPAIR
 XP-5504 QUIK PLASTIK *EPOXY PLASTIC REPAIR
 XP-5505 REPAIR-IT-QUIK *EPOXY MULTI PURPOSE REPAIR
 XP-5506 QUIK COPPER *EPOXY COPPER REPAIR
 XP-5507 QUIKWOOD *EPOXY WOOD REPAIR
 XP-5508 QUIK ALUMINUM *EPOXY ALUMINUM REPAIR
 XP-5510 601 *ONE PART SILICONE SEALANT & CAULK BLACK, CLEAR & WHITE
 XP-5520 803 *ONE PART URETHANE SEALANT BLACK, GREY, WHITE
 XP-5530 952 *ONE PART SELF LEVEL POLYURETHANE 30-0Z GREY

PEST CONTROL
 XN-6000 MOUSE GLUE BOARDS
 XP-6000 B.V.T. KONK *FLYING INSECT KILL
 XR-6000 DEMISE *POWDER FIRE ANT & INSECTICIDE 6 X 6OZ
 XR-6005 SNIPER *FAST ACTING INSECT KILLER
 XR-6010 EXTING *CONCENTRATE- 2.5% PERMETHRIN
 XR-6015 EXTING *RTU 0.5% PERMETHRIN RESIDUAL KILL
 XR-6020 TOTAL RELEASE *ROOM FOGGER INSECT KILL
 XR-6025 DBUG *ALL NATURAL 6-LIMONENE BASED LIQUID KILL
 XR-6030 DUEL *FLYING AND CRAWLING INSECT KILL
 XR-6040 BUG BAND *PUMP DIET FREE INSECT REPELLENT
 XR-6100 C.I.K. *VANILLA SCENTED CRAWLING INSECT KILLER
 XR-6105 LONG SHOT *WASP AND HORNET KILL
 XR-6104 ZENKILL IV *MULTI-PURPOSE INSECT SPRAY
 XR-6105 F.I.K. *FLYING INSECT KILL QUICK KNOCK DOWN
 XR-6110 CONTACT CAKE *RODENTICIDE BAIT LBS
 XR-6120 BEAT-IT INSECT REPELLANT PUMP SPRAY 25% DEET 4oz

SEWER & DRAIN
 XL-6500 LIFT ASSIST *FLOATING DEGREASER
 XL-6505 LIFT ASSIST II *DEGREASER SOLVENT BLEND FORMULA 50/50
 XL-6510 LIFT ASSITS III *100% PURE ORANGE SOLVENT
 XL-6520 BHO BUG *EUCALYPTUS ENZYMATIC TREAT FOR ORG. WASTE
 XL-6525 BHO BUG *CITRUS ENZYMATIC TREAT FOR ORGANIC WASTE
 XL-6530 BHO BUG *BERRY ENZYMATIC TREATFOR ORGANIC WASTE
 XL-6550 SOQEYK CLEAN *NATURAL CLEAN SOLVENT/ORGANIC
 XL-6560 DR. Z BHO WASTE DEGRADER NON-TOXIC, ACID, ALKALINE

SEWER & DRAIN CONT
 XL-6575 SHOOPLY II *THICKEN
 XL-6580 SUSPENSE *SANITARY
 XL-6590 GAME BUSTER *CONCENTRATE DRAIN & TRAP TREATMENT
 XL-6600 RAGING BULL *GREASE TRAP TREATMENT
 XL-6620 DOUBLE PLAY *LIQUID DRAIN & TRAP CLEANER
 XL-6640 MAIN ATTRACTION *MAIN LINE CLEANER
 XL-6650 Z-MANO *BIODEGRADABLE SEPTIC TANK TREATMENT
 XL-6660 ALL OON *BACTERIAL SOAP DEGRADER
 XL-6710 DESTROYER *BACTERIAL DIGESTANT, ENZYME SYSTEM
 XL-6900 RESCUE *ALKALINE DRAIN OPENER
 XN-6540 SLAMMA HAMMA *GRANULAR SEWER SOLVENT
 XN-6550 SLAMMA HAMMA II *RED HOT SEWER SOLVENT GRANULAR
 XN-6580 POWDER KED *TOSSE IN BLOCKS FOR SEWER, GREASE TRAPS
 XN-6610 SAK-FORCE *SOLID GREASE TRAP CONCENTRATE 2LBS
 XN-6630 OPEN SEZME *ECONOMICAL BACTERIAL DRAIN CLEANER
 XN-6670 GAR-FACE *BACILLUS BACTERIA, IN SOLUBLE PACK
 XN-6680 CANNIBAL *POWDER LARGE VOLUME BLD TREATMENT
 XN-6690 DOWN THE HATCH *HD CRYSTAL DRAIN OPENER
 XR-6589 DRAIN POWER *SULFURIC ACID DRAIN OPENER
 XR-6599 QUICK FIX *ACID DRAIN OPENER WOODOR BLOCK

SKIN CARE
 XL-7000 GUARDIAN *PROFESSIONAL BARRIER SKIN CREAM II oz.
 XL-7010 REBEL *INDUSTRIAL HAND CLEANER
 XL-7100 NITTY GRITTY *ORIGINAL PUMICE HAND SOAP 4.5
 XL-7102 NITTY GRITTY *ORIGINAL PUMICE HAND SOAP 2oz TUBE
 XL-7110 NITTY GRITTY *ORANGE PUMICE HAND SOAP 4.5
 XL-7112 NITTY GRITTY *ORANGE PUMICE HAND CLEAN 24oz TUBE
 XL-7120 BY-GEBORGE *CHERRY PUMICE HEAVY DUTY CHERRY
 XL-7130 SMOOTHIE *ORIGINAL HEAVY DUTY HAND CLEAN 4.5
 XL-7132 SMOOTHIE *ORIGINAL HEAVY DUTY HAND CLEAN 2 TUBE
 XN-7000 HEALTH GUARD *ANTIBACTERIAL HAND SOAP
 XN-7065 CLEAN SHAPE *LIQUID ANTI-BACTERIAL HAND SOAP
 XN-7067 CLEAN SHAPE *FOAMING ANTI-BACTERIAL HAND SOAP
 XN-7010 SUPER SCRUB *GREEN HAND CLEANER WITH SCRUBBERS
 XN-7020 GREEN LOTION *HD GENERAL PURPOSE HAND CLEANER
 XN-7030 PINK LOTION *SOFT & SILKY HAND SOAP
 XN-7040 SLUMMA *ANTI-BACTERIAL LOTION SOAP
 XN-7050 GOLDEN ANTI-BACTERIAL *LIQUID HAND SOAP
 XN-7060 KML *MOISTURIZING HAND & BODY LOTION
 XN-7070 HSC-E-2 HAND CLEANER & SANITIZER
 XN-7080 WISSK FOAMING INSTANT HAND SANITIZER
 XR-7090 515 INSTANT HAND SANITIZER ALCOHOL BASED GEL

SPECIALTY
 XL-7505 CHERRY CONCENTRATED LIQUID DEODORANT
 XL-7510 STER-FAB #11 WAY INSECTS FUNGUS GERMS AND ODOORS
 XL-7550 FLPPER *INCREASES PENETRATING ABILITY OF WATER
 XL-7560 FIRE FIGHTING FOAM CLASS A & B
 XN-7500 VCI EMITTERS *STICK-ON CORROSION PROTECTION
 XN-7550 FLO-TABS *CONDENSATE PAN TREATMENT
 XN-7600 PAN-GEL TABLETS *DRAIN PAN GEL TABS 5-TON
 XN-7610 PAN-GEL TABLETS *DRAIN PAN GEL TABS 7 1/2-TONS
 XN-7620 PAN-GEL TABLETS *DRAIN PAN GEL TABS 15-TON
 XN-7665 CITRA CRYSTAL *HD CONCRETE & EQUIPMENT CLEANER
 XR-7510 ANTI CLOG #1 BLOCK (TREATS UP TO 15 TON UNITS)
 XR-7520 ANTI CLOG #1 SLIM STRIP (TREATS UP TO 5-TONS UNITS)
 XR-7530 ANTI CLOG #1 BRICK (TREATS UP TO 45-TONS UNITS)
 XR-7540 ANTI CLOG #1 SQUARE (TREATS UP TO 5-TON UNITS)

SOLVENTS
 XA-8010 REAL MCKOY *SAFETY SOLVENT / DEGREASER
 XA-8020 MR. MECHANIC *4 WAY PENETRANT / LUBRICANT
 XA-8040 EASY RIDER *NON-FLAMMABLE BRAKE CLEANER
 XA-8045 NU SHOE *BRAKE CLEANER
 XA-8050 ORANGE PEEL *ORGANIC SOLVENT CLEANER DEGREASER
 XA-8060 PRECISION *CONTACT CLEANER NON FLAMMABLE
 XA-8071 SLICE *HD ORANGE DEGREASER AND TAR REMOVER
 XA-8090 AGGRESSIVE *FAST ACTING SOLVENT DEGREASER CITRUS
 XA-8100 STRIPPERS GEL *PAINT & VARNISH REMOVER
 XA-8110 ONKEY DO-KEY *GASKET, ADHESIVE & DECAL REMOVER
 XA-8120 ELECTRO *ADVANCED SAFETY SOLVENT
 XA-8130 FLASH *HIGH PRESSURE BLAST COIL AND FIN CLEANER
 XA-8140 GANGSTA *SUPER GEL VANDALISM REMOVER
 XA-8150 BUST'N LOOSE *PENETRATING OIL LUBRICANT
 XL-8010 REAL MCKOY *LIQUID CHLORINATED CLEANING SOLVENT BULK
 XL-8020 NU SHOE *BRAKE CLEANER BULK
 XL-8060 BUZZ SAW *CONCENTRATED NON-BUTYL CLEANER
 XL-8070 UPPER CUT *INSTANT DEGREASER & TOOL COOLANT ONLY 55 GAL
 XL-8080 ORANGE PEEL *LIQUID ORGANIC SOLVENT DEGREASER
 XL-8090 PWS *MULTI PURPOSE PARTS WASHING SOLVENT
 XL-8100 STRIPPER GEL *PAINT & VARNISH REMOVER BULK
 XL-8200 SALTTRUSTER *SALT & CHLORIDE NEUTRALIZER

WIPES
 XW-8500 MR. MAGIC *MELAMINE SPONGES
 XW-8510 MONK BUCKET OF WIPES 72/WIPES PER CONTAINER
 XW-8530 MONK WIPES 140 COUNT BUCKETS
 XW-8540 MONK TOWELETT'S SINGLE PACK
 XW-8550 WIZARD WIPES *MULTI-PURPOSE 9.5 X 12 130 COUNT
 XW-8560 WIZARD WIPES *HAND CLEANING WIPES
 XW-8570 WIZARD WIPES *STAINLESS STEEL CLEAN & POLISH WIPES
 XW-8580 WIZARD WIPES *RUBBER, VINYL, LEATHER PROTECTANT WIPES
 XW-8590 WIZARD WIPES *WHITBOARD CLEANING WIPES
 XW-8600 WIZARD WIPES *LINT FREE GLASS CLEANING WIPES
 XW-8610 WIZARD WIPES *FURNITURE & WOOD CLEANING WIPES
 XW-8620 WIZARD WIPES *GRAFFITI REMOVING WIPES

WINTER
 XA-9001 JACK FROST *WINDSHIELD, WINDOW AND LOCK DE-ICER
 XL-9020 LIQUID ICE MELT *NON-CORROSIVE FORMULA
 XN-9010 MELTY *CALCIUM CHLORIDE ECO DRUM CONTAINER

- Other Specialty Products
- Complete Water Treatment Line
 - Boiler & Cooling Tower Treatment

(800) 634-1114

WIEMATION TRAXX RITE HELPS KEEP YOU TRACKING WITHOUT EDGE DAMAGE

Traxx Rite® is our patented sprocket-driven line of woven wire conveyor belts. The positive driven belt ensures precision tracking of your conveyor and eliminates belt slippage in wet or oily conditions. Traxx Rite® belting is offered in a wide array of opening sizes and wire diameter. Traxx Rite® is ideal for any application that needs air flow to cool the product, openings so that any breaching or batter can easily fall through or tighter weave for smaller products to stay put for further processing. The splicing process is as simple as any balance weave belting you may already use, but much easier than other types of open surface area belting. Our Traxx Rite® line of belting is FDA approved to be used in all food processing applications. We have designed an abbreviation of the normal 8-10 character specifications to simplify the ordering process. Please contact us if you have any questions on these.

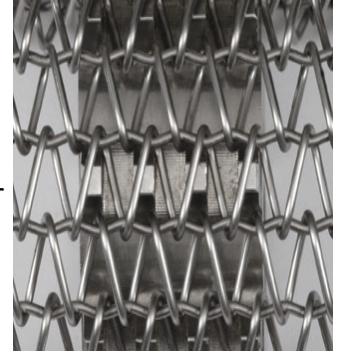

WIEMATION CLEANS UP YOUR OILY PROBLEMS WITH IT'S FILTER BELT

Filter Belts Any plant that is frying is a likely Filter Belt customer. Filter Belts are most commonly used in the Stein SF Series Continuous Force Flow Filter, which is, by far, the most common system used in the industry. These belts are used to filter the oil used in the fryer, extending the life of the frying oil and minimizing the formation of fatty acids. Filter belts can remove particles as small as 80 micron or 60 micron. After the particles are removed from the oil, they are removed from the belt by a scraper for reclamation or recycling.

In addition to the 316 SS Reverse Double Dutch weave mesh material and the low profile alligator lace, contact us to tell you the other features why our filters do a better job, and last longer.

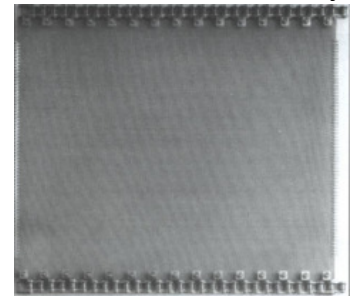

SPIRAL BELTS, INSTALLATION AND SERVICE

Ashworth, the inventors of the low tension spiral systems, are manufacturers of turn curve belts made from metal, hybrid metal and plastic. We can design, inspect, repair, retrofit, rebuild and install a belt for you.

Let the experts work on your spiral. You will see the difference from the beginning through the work and installation. Call today and let us show you how we can help you with the latest designs, applications and products, including our Self Stacking Belt, the ExactaStack™.

www.bsandk.com

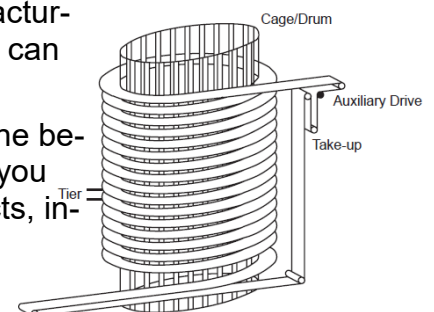



REMCO KEEPS YOUR WORKPLACE CLEAN AND SANITARY

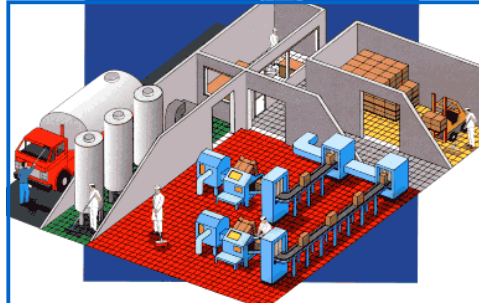

Products from **REMCO** can be color-coded to help divide the production cycle into different zones or tasks. By identifying these as different cleaning areas, the movement of contaminants around the production area can be effectively blocked.

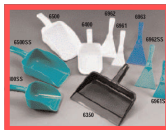

Let **BS&k** show you how **REMCO** products can clean up your sanitation problems and let you get back to what you do best, that is, running your business.



BS&k COMPANY INTEGRATES LOCAL SERVICE WITH NATIONAL KNOWLEDGE

The BS&k company has been providing local service to companies for 10 years.

Knowledge we have gained from working with national companies has allowed us to service companies locally, the way most national companies get serviced.

With 30 years experience in sales and manufacturing environments, we know how critical it is to you to have your lines up and running, when you need them up and running. We won't let you down!

Let us work with you and provide the following:

- *Plant Surveys*
- *Complimentary Product lines*
- *Competitive Pricing*
- *On-site troubleshooting*
- *Installation Assistance*
- *Order History Analysis*
- *Stocking Plans*

Contact us today and let us show you what we can do for you.

We have a CD with our literature, catalogs and other information on it. Let us send one to you.

(800) 634-1114 (Toll free)
 (704) 365-6408 (Local)
 (704) 365-3578 (Fax)

www.bsandk.com

bob@bsandk.com



john@bsandk.com



Sue@bsandk.com



Featured Application

Application: Stainless Steel and Painted Steel Lifting Devices

Principal: SuperLift



SuperLift is A North American Supplier of Industrial Lifting & Handling Equipment including:

- Column lifts, Mezzanine lifts, Ingredient lifts
- Lift Tables, Pallet Lifts and Tilters
- Low Profile and ground level lifts
- Man lifts and inverters
- Pallet Trucks and lift trucks
- Tuggers, pushers and stackers
- ◆ Ergonomic and Custom Lifts
- ◆ They also specialize in the custom manufacture of any lift device you can come up with. All Capacities are from 500 to 200,000 lbs

Product: Stainless Steel Scissor Lifts.

- Capacities from 250 lbs to 20,000 lbs
 - Standard lifts, ground level, lift and tilts, double lifts, low profile, heavy duty all available
 - 304 and 316 stainless steel polished #4 or mirror finishes
 - Stainless steel cylinders or ball screw units for precision applications
 - Lift heights to 120"
- Powered drive also Available.
 - Powered by air, hydraulic or electric ball screw



(704) 365-6408